

Installation instructions

for floating installation

Dear customer,

We thank you for purchasing our Parky floor.

Before starting the installation, it is essential to read these instructions carefully. If these instructions are not followed, the instructor will be deemed fully responsible.

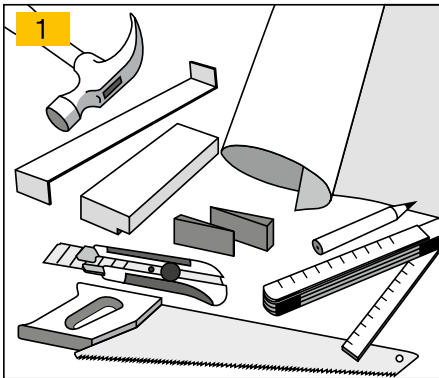

INSTALLATION MATERIALS (picture 1)

- Parky Installation Kit
(Hitting block - Expansion spacer - Striking bar)
- Quality underlay:
 - Parky WITH an integrated cork layer:
Damp-proof foil
 - Parky WITHOUT an integrated cork layer:
Basic or Silent underlay
- Hammer
- Parky waterproof tape
- Pencil
- Saw
- Cutter
- Meter

Do not use glue, screws or nails during the floating installation of Parky. For glued-down installation, see <https://www.par-ky.com/media/files/eng-installation-instructions-glue-down-installation.pdf>

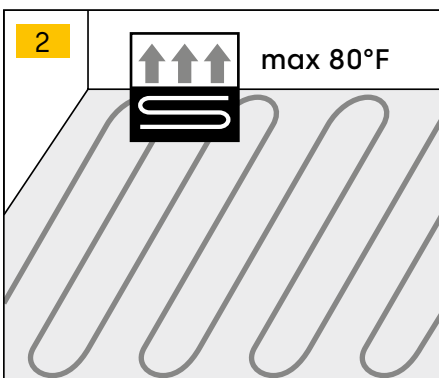

UNDERFLOOR HEATING (picture 2)

Parky floors can be installed over underfloor heating. Follow the instructions of the floor heating manufacturer. The maximum allowed contact temperature is 80°F. You can find our installation instructions on www.par-ky.com.

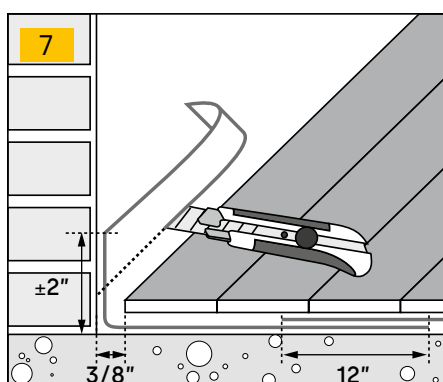
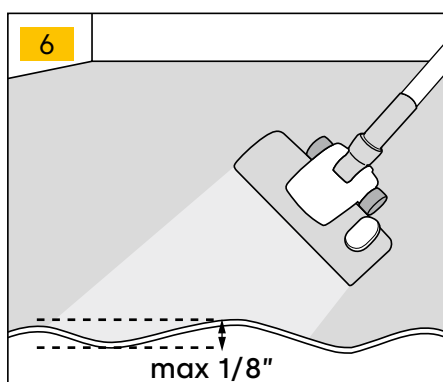
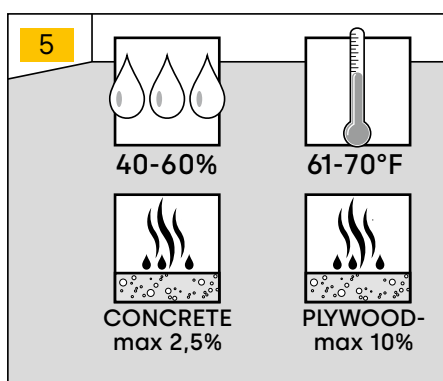
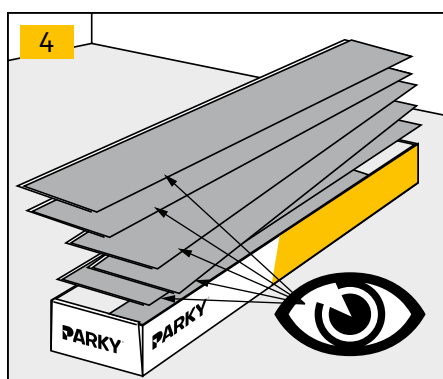
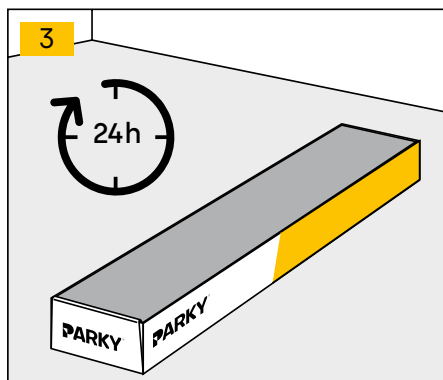

STORAGE: Store Parky floors in a perfectly dry and protected room with an air humidity of 40 to 60% and a temperature of 61 to 70° F. In order to prevent deformation, the boxes may not come into contact directly with the ground.

Warning: Do not open the boxes until the moment of installation.

PREPARATIONS: Put the Parky boxes in the relevant room 24 hours before installation. Put the boxes in the middle of the room and certainly not against a wall. (picture 3) Open the packs just before installation. Check every board carefully. Do not install boards with defects. (picture 4)

Remark: Veneer flooring is a natural product and therefore unique so no boards are identical. Minor variations in colour and structure are normal. Small natural marks such as knots and mineral streaks are tolerated and have no effect on the quality of the floor. We strongly advise to use the same production batch per room in order to obtain the most uniform result. You can find the production number on the backing of each board and we highly recommend not to mix 2 different batches.

Defects in the under floor have to be repaired.

The under floor must be:

- Clean and dust free
- Sound with no loose particles.
- Flat. The maximum difference in height is 1/8" over 6' 9/16". Any unevenness of more than 3/64" over a length of 7 7/8" must be levelled out.
- Dry. The humidity needs to be less then 2.5% for installation in screed without floor heating, 2% in screed with floor heating, 0.6% in anhydritescreed and 10% in multiplex.

In principle, Parky can be installed on any underfloor that is solid and sound. The ideal fitting circumstances are a temperature between 61°F and 70°F and an atmospheric humidity between 40% and 60%. (picture 5 and 6)

UNDERLAY (picture 7)

• For the collections with an integrated cork layer, we recommend to use our 150 micron Parky damp screen under the floor. Allow an overlap of 12", stick the edges of the foil together with Parky moisture-resistant tape and make sure there are no holes in the foil. Put the foil 2" up the wall to avoid moisture under the flooring.

• If your floor doesn't have an integrated cork layer, use our Basic or Silent underlay. In humid climates or when there is a humidity risk in the wall, we suggest to fold the underlay ± 2" up to the wall or use waterproof tape to seal the underlay against the wall. This to avoid that humidity damages the floor.

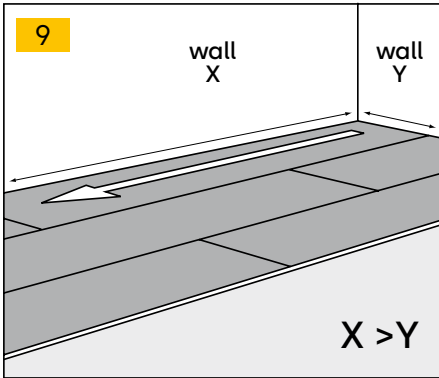
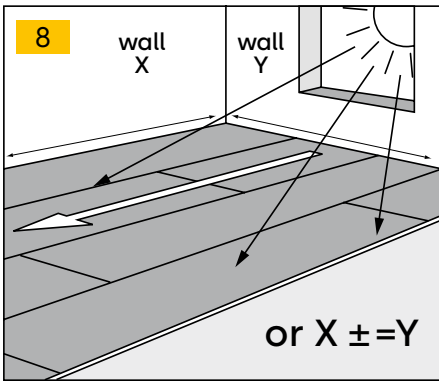

LAYOUT (picture 8 and 9)

We recommend to install the floor towards the light or in the direction of the longest wall.

Remark: Some wood species are sensitive to colour variations under the influence of UV light. It is a natural phenomenon that colours darken or lighten in the course of time.

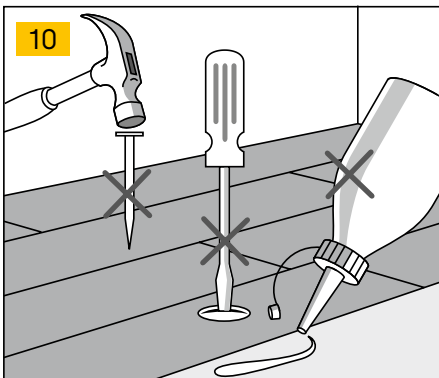

INSTALLATION

Parky uses the Unifit X® system (picture 12) for the installation of floating floors without using adhesive. The floorboards are held together using a click tongue-and-groove system.

This system allows faster, fault-free laying.

Parky is a real wood floor. Sufficient expansion gaps should therefore be left along each wall, around heating pipes, and around obstacles on the surface (for example door frames).

The minimum expansion gap is 3/8" or 3/64" per 3'3".

The expansion gaps can be covered with skirtings attached to the wall, but NEVER to the floor. For floors that are longer or wider than 33', an additional expansion gap must be provided using a T-profile (picture 11)

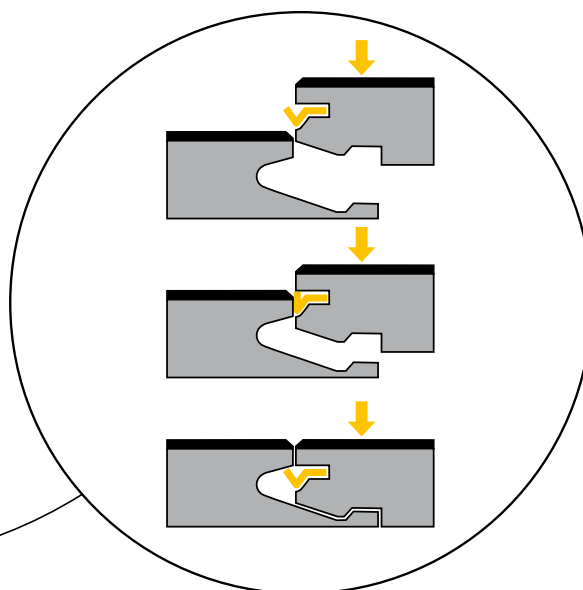
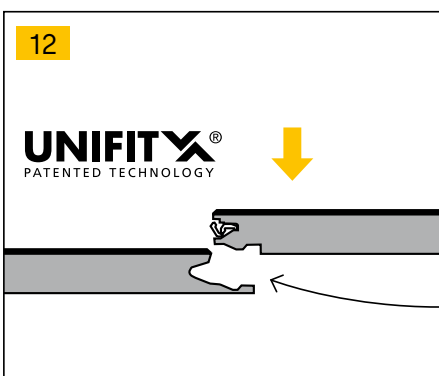
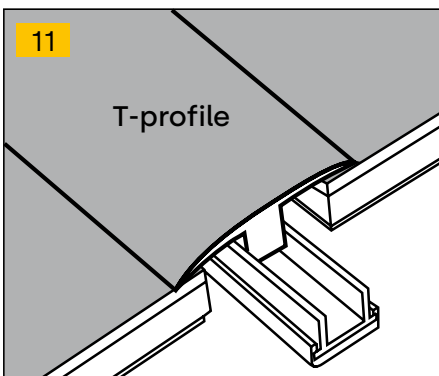

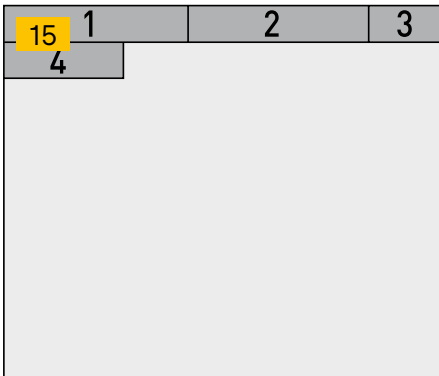
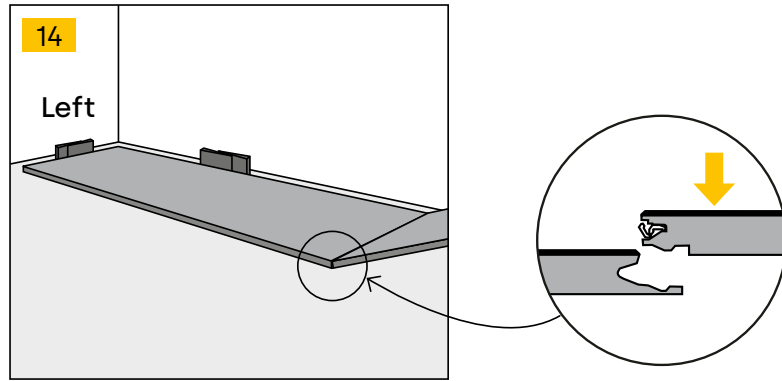
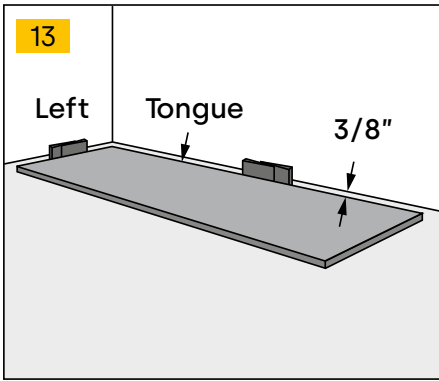

Place the Parky floor parallel to the long wall of the room. Place the floors from left to right, with the tooth side facing the beginning wall.

Place spacers that serve as 3/8" expansion joints. **(picture 13)**. Installation is very easy thanks to the Unifit X[®] system. The end connection of a board can be most easily and safely installed by pushing the connection down. **(picture 14)**. A rubber hammer can be useful to check the connections a second time and, if necessary, to tap gently.

Place the first 2 rows according to the picture.

By placing the first 2 rows as shown on the image you will get a straight edge to start the rest of the placement. The sawn-off pieces of the first and second rows usually form the perfect starting boards for the third and fourth rows. Always use spacers to maintain the correct distance from the wall. **(picture 15 & 17)**

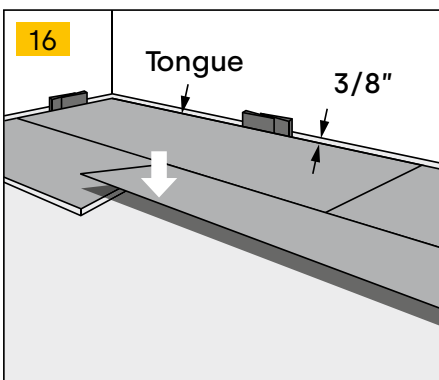

Lift the next board at an angle of 20 to 30 degrees, push the board into the groove on the long side and carefully slide it to the left until it touches the end of the previously laid board. Push the board down firmly towards the floor and thanks to the Unifit X[®] system the connection in the end fits perfectly. Always check each joint before proceeding (tap them carefully with a rubber hammer and tapping block if necessary). **(picture 16)**

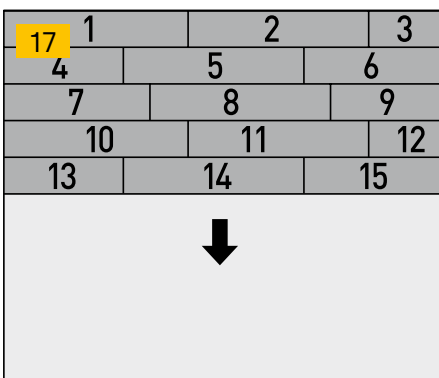

The last row

Leave again an expansion gap of 3/8" between the last board and the wall. Cut the boards of the last row in the length. To click the boards in the second last row, use the metal striking bar from the installation kit. **(picture 18)**

Doorframes

Cut the boards and make sure there is an expansion gap of 3/8". Use the striking bar in case it is not possible to click the board. **(picture 19 and 20)**

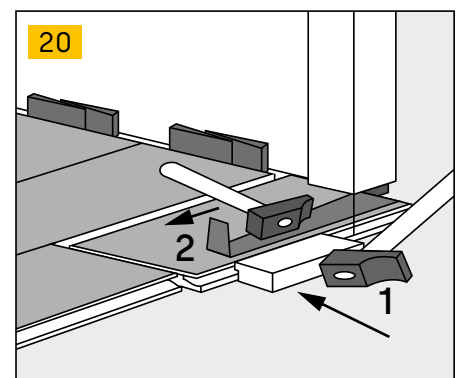
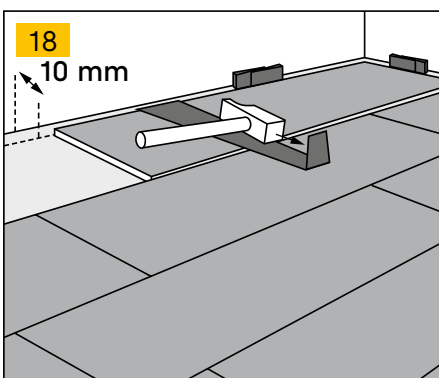

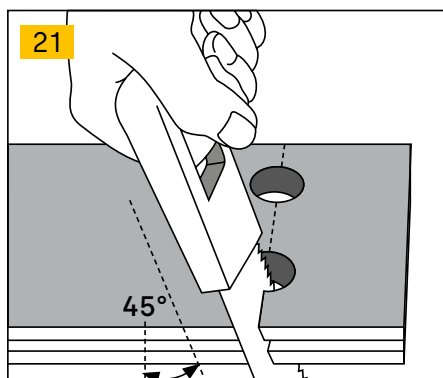

Heating pipes

Watch the picture carefully how to cut a Parky board. It is important to follow the instructions to achieve a nice result. Around the pipes you can finish the floor with silicone. It is important that the expansion gap is closed off to avoid moisture in the Parky floor. (picture 21 and 22)

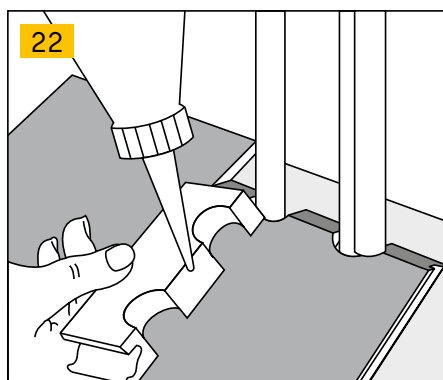

The finish

Due to the fact that the floor is installed without glue, you can immediately walk on the floor after installation. Remove all spacing blocks and install the skirtings. Never fix the skirtings to the floor, but always to the wall. The floor needs to expand and contract under the skirting. Use silicone where you are not able to use a skirting.

In general; the floor has to be sealed to avoid penetration of moisture.

MAINTENANCE AND PROTECTION

For an optimal protection of your Parky floor, put:

- A. Pieces of felt under the chairs.
- B. Parquet wheels under office chairs and a protection mat under the chair.
- C. A doormat if the floor is installed at the entrance.

Use the Parky cleaner to maintain your Parky Wood Floor Cleaner. Parky Wood Floor Cleaner removes the dirt without harming the lacquer and it gives your floor a nice look. Contact your dealer for stubborn spots.

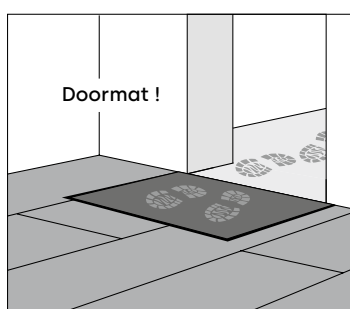
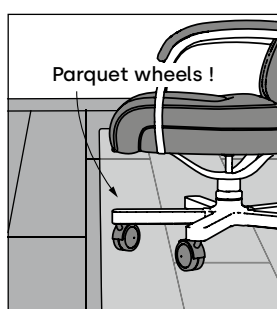
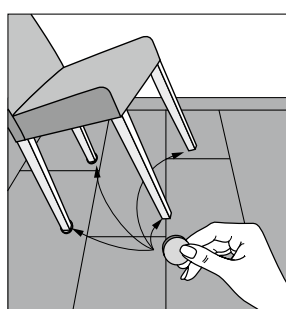

PARKY[®]
It's good to live on wood

If you have any questions, don't hesitate to contact your local dealer or the head office in Belgium.

Decospan nv, Industriezone Grensland
Lageweg 33, 8930 Menen - Belgium
tel +32 56 52 88 49 - info@par-ky.com
www.par-ky.com

DECOSPAN